



Data Sheet

YXP010 – 10 sec

YXP021 – 21 sec

YXP042 – 42 sec

深圳宇芯科技发展有限公司

[Shenzhen Yuxin Technology Develop.Co.,Ltd](#)

Address: 深圳市宝安区43区安乐工业区4栋二楼

TEL: (0755) 26645662/26416647

QQ: 124202580

MB: (+86) 013715113997

FAX: (0755)26645695

E-mail: yuxin0011@163.com

RUL: <http://www.yuxinic.com>



YXP Series

FEATURES

- Embedded OTP memory and 8-bit MCU
- Built-in oscillator and Power On Reset circuits to reduce external components.
- 2.2V – 3.6V single power supply and < 5uA low stand-by current.
- 10, 21 and 42sec voice duration at 6 KHz sampling with 4-bit ADPCM compression.
- Combination of voice building blocks to extend playback duration.
- Table entries are available for voice block combinations.
- User selectable PCM or ADPCM data compress.
- Voice Group Trigger Options: Edge / Level; Hold / Un-hold; Retrigger / Non-retrigger.
- Programmable I/Os, Timer Interrupt and Watch Dog Timer.
- PWM Vout1 and Vout2 drive speaker directly with 2 levels volume control.
- D/A COUT with ramp-up ramp-down option to drive speaker through an external BJT.
- Windows based development system and USB programmer support.

DESCRIPTION

YXP is a 8-bit CPU based Voice chip series. It is fabricated with Standard CMOS process with embedded voice storage OTP memory. It can store from 10 to 42sec voice message with 4-bit ADPCM compression at 6KHz sampling rate. 8-bit PCM is also available as user selectable option to improve sound quality. Depending on IC body, there are up to eight programmable I/O pins. Key trigger and Parallel CPU trigger mode can be configured according to different application requirements. User selectable triggering and output signal options provide maximum flexibility to various applications. Fully integrated system oscillator, power-on reset, 8-bit current mode D/A output and PWM direct speaker driving output to minimize external components count. Two level volume control for PWM direct speaker driving output.

Part Number	Duration	Programmable IO
YXP010	10sec	4
YXP021	21sec	4
YXP042	42sec	8

PIN CONFIGURATIONS

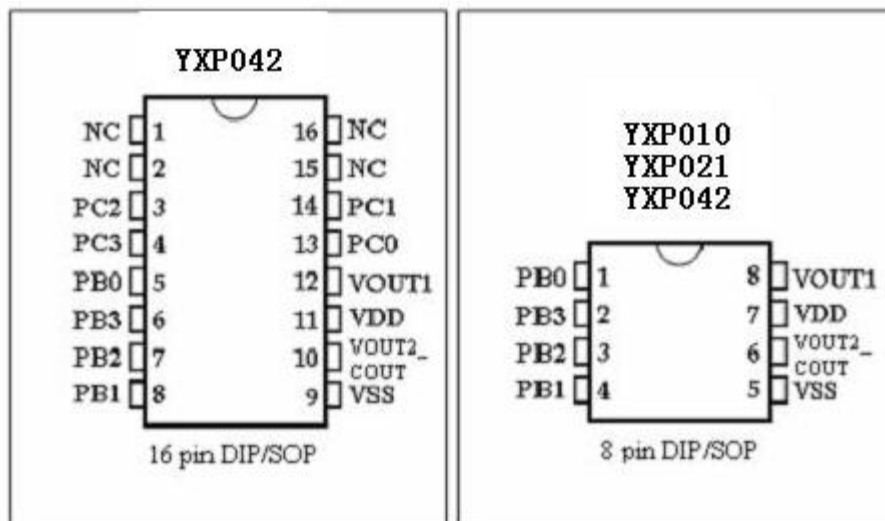

Note: 16 pins and 8 pins packages are available for YXP042

PIN DESCRIPTIONS

Pin Names	Description
VOUT1	PWM output to drive speaker directly
VOUT2_ COUT	PWM output or COUT DAC output select by programmable option (COUT is not available on YXP010)
VSS	Power Ground
VDD	Positive Power Supply
PBm	Programmable I/O pins (m: 0 to 2)
PB3	Input pin with programmable pull-down
PCn	Programmable I/O pins (n: 0 to 3 for YXP042 only)

Note:

1. Pins required for OTP program include PB0 to PB3, VOUT1, VOUT2_COUT, VDD and VSS.
2. PBm and PCn are software programmable I/O pins that can be set to different configurations such as pure input, input with pull-up, input with pull-down and output. The programmable I/O pins set up will take effect immediately after power-on reset.
3. 8-pin and 16-pin packages are available for YXP042.

BLOCK DIAGRAM

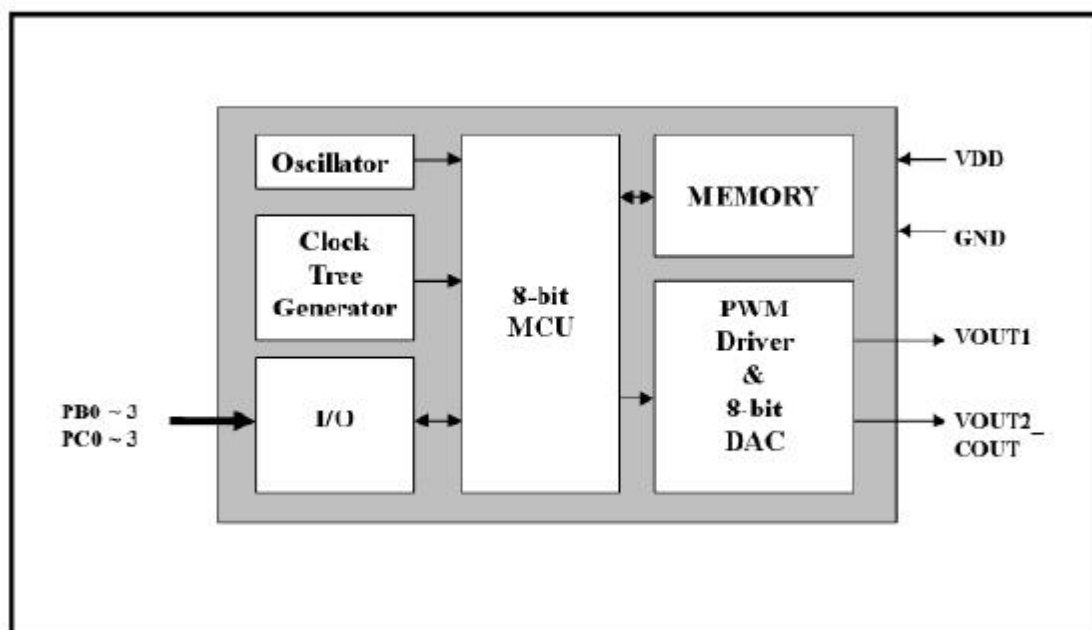

ABSOLUTE MAXIMUM RATINGS

Symbol	Rating	Unit
$V_{DD} - V_{SS}$	-0.5 ~ +4.0	V
V_{IN}	$V_{SS} - 0.3 < V_{IN} < V_{DD} + 0.3$	V
V_{OUT}	$V_{SS} < V_{OUT} < V_{DD}$	V
T (Operating):	-40 ~ +85	°C
T (Junction)	-40 ~ +125	°C
T (Storage)	-55 ~ +125	°C



YXP Series

DC CHARACTERISTICS ($T_A = 0$ to 70°C , $V_{DD} = 3.0\text{V}$, $V_{SS} = 0\text{V}$)

Symbol	Parameter	Min.	Typ.	Max.	Unit	Conditions
V_{DD}	Operating Voltage	2.2	3.0	3.6	V	
I_{SB}	Standby current	—	1	5	μA	I/O properly terminated
I_{OP}	Operating current	—	4	15	mA	I/O properly terminated
V_{IH}	"H" Input Voltage	2.5	3.0	3.5	V	$V_{DD}=3.0\text{V}$
V_{IL}	"L" Input Voltage	-0.3	0	0.5	V	$V_{DD}=3.0\text{V}$
I_{VOUTL}	V_{OUT} low O/P Current	—	130	—	mA	$V_{out}=1.0\text{V}$ (Note 1)
I_{VOUTH}	V_{OUT} high O/P Current	—	-130	—	mA	$V_{out}=2.0\text{V}$ (Note 1)
I_{CO}	C_{OUT} O/P Current	—	-2	—	mA	Data = 80h
I_{OH}	O/P High Current	—	-5	—	mA	$V_{OH}=2.5\text{V}$
I_{OL}	O/P Low Current	—	20	—	mA	$V_{OL}=0.3\text{V}$
R_{NVOUT}	V_{OUT} pull-down resistance	—	100K	—	Ω	V_{OUT} pin set to internal pull-down
R_{NPB3}	Programmable IP pin pull-down resistance	—	1M	—	Ω	PB3 is set to internal pull-down
R_{NPIO}	Programmable IO pin pull-down resistance	—	1M	—	Ω	PBm, PCn, are set to internal pull-down
R_{UPIO}	Programmable IO pin pull-up resistance	3.3K	4.7K	—	Ω	PBm, PCn, set to internal pull-up
$\Delta F_s/F_s$	Frequency stability	-3	—	+3	%	$V_{DD} = 3\text{V} \pm 0.4\text{V}$
$\Delta F_c/F_c$	Chip to chip Frequency Variation	-5	—	+5	%	Also apply to lot to lot variation

Note:

1. The current value is for normal volume. It is double for high volume. The V_{OUT} volume is selected by using the development system software provided.
2. Where PBm stands for programmable I/O pins PB0, PB1 and PB2; PCn stands for programmable I/O pins PC0, PC1, PC2 and PC3.

TYPICAL APPLICATIONS

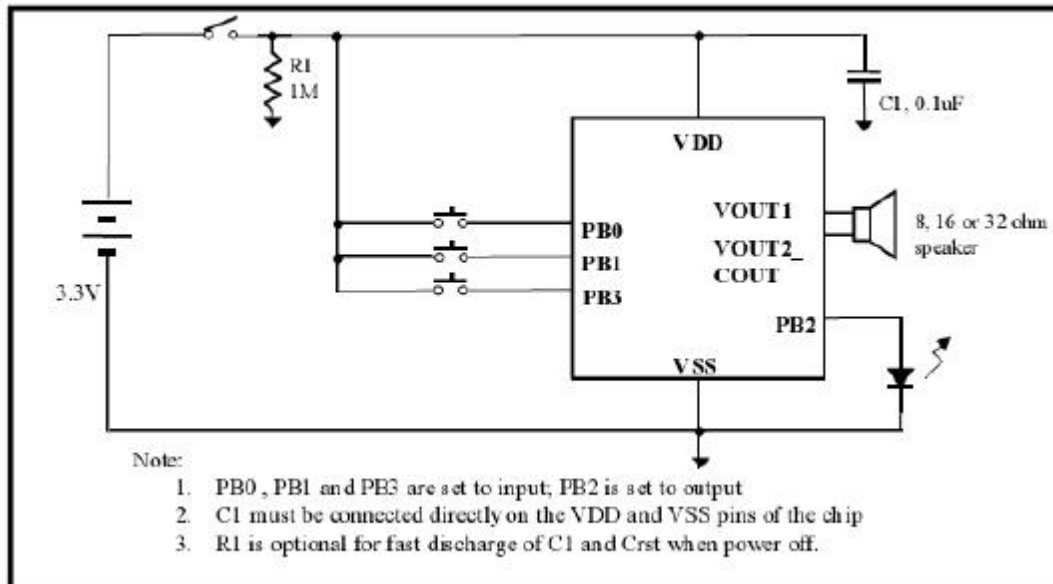

Using 3.3V Battery with speaker direct drive

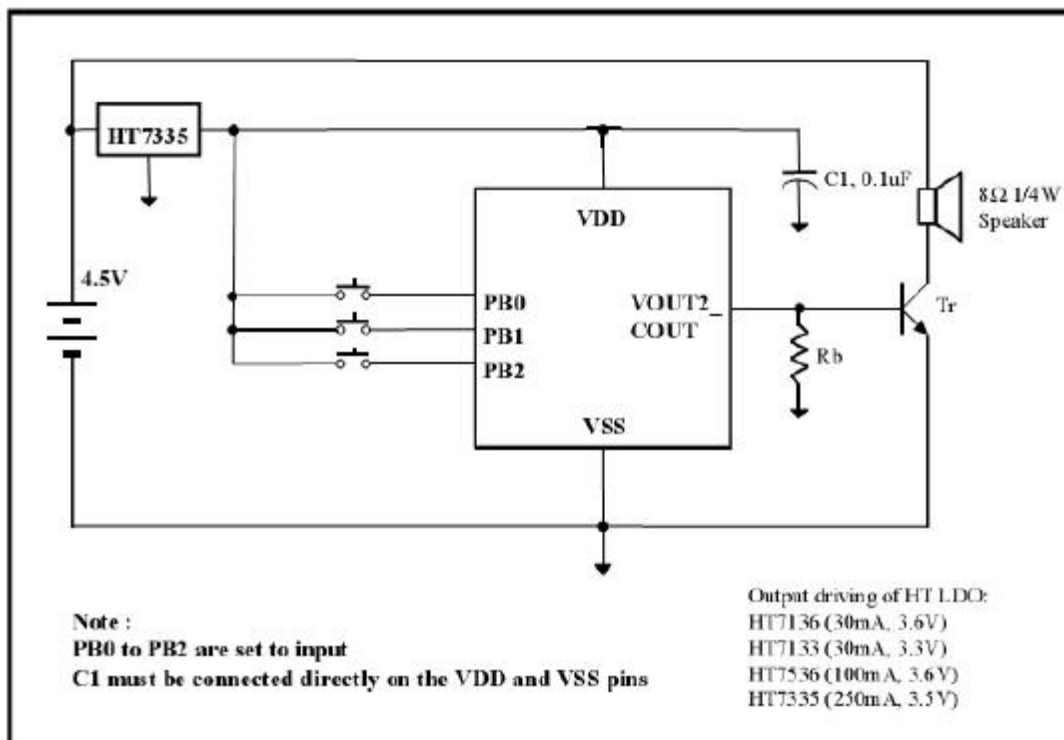

Using 4.5V Battery with COUT speaker drive

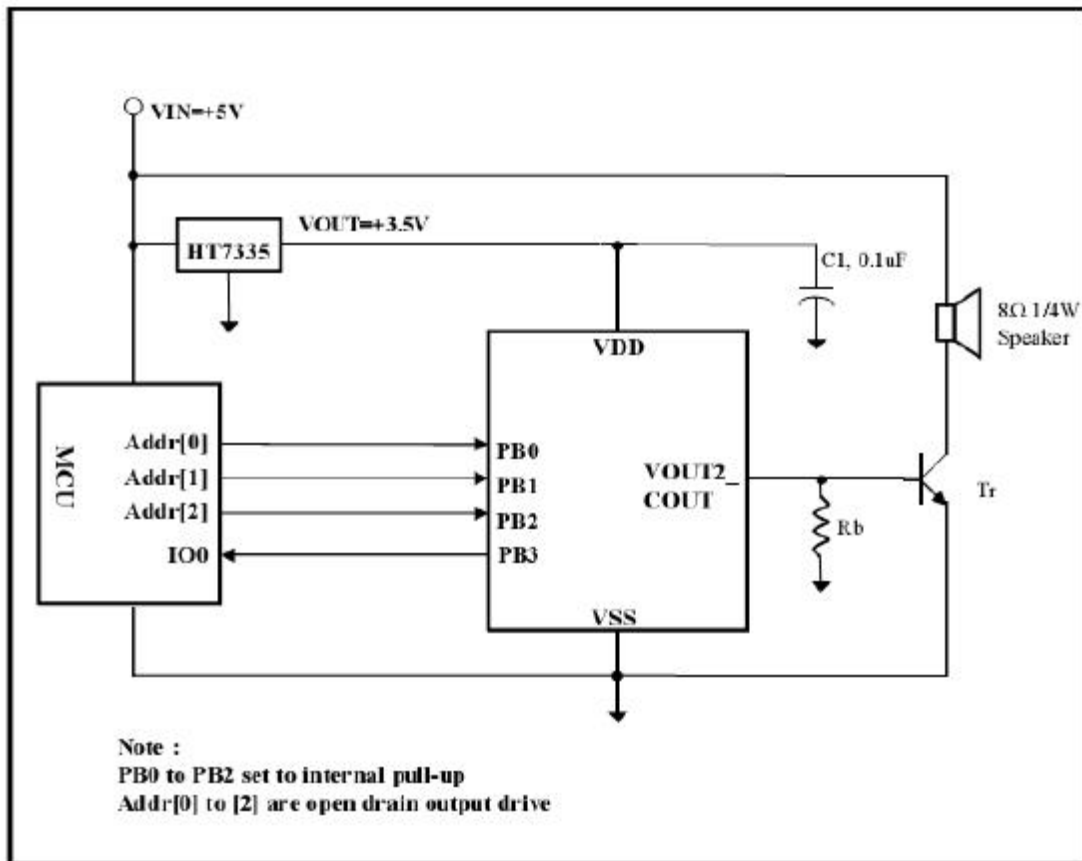

5V CPU Control with COUT

Note for COUT speaker drive:

1. C1 must be connected as close to the chips VDD and VSS pins as possible.
2. Rb is base resistor from 120 Ohm to 390 Ohm depends on value of VDD and transistor gain.
3. Tr is an NPN transistor with beta larger than 150, e.g. 8050D.



YXP Series

Bonding Diagrams (pad opening 70x70um, substrate should be connected to VSS)

